

# CPI 1.25 kW SuperLinear® Touchscreen TWTA

## For Satellite Communications Uplink Applications

Provides 1250 watts of peak power in a 5 rack unit package, digital ready, for wideband satellite service within the Ku-band frequency range.

### Touchscreen Graphical Interface

State of the art touchscreen interface with both amplifier and/or system level control capabilities. Includes fault logs, parameter trending and scopescreen for monitoring performance. Internal switch control eliminates need for external controllers.

### Super Efficient, Easy to Maintain

Modular design and built-in fault diagnostic capability with convenient and clearly visible indicators for easy maintainability in the field. A USB port is available for uploading new firmware and system configurations, and downloading logs and system configurations for cloning to other units. Consumes only 2.3 kVA to produce 540 W of output power.

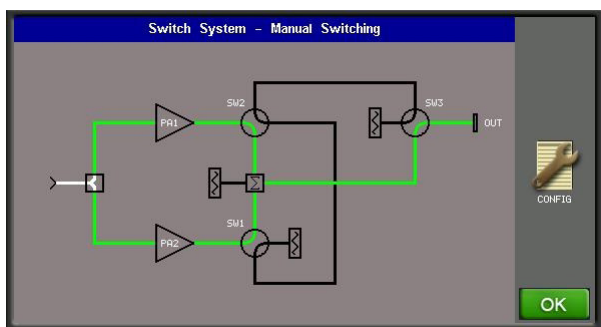

Touchscreen TWTA Sample Redundancy System Schematic Display; Various Configurations Available



CPI 1250 W Ku-band TouchPower™ TWTA Model T5UI-12

### OPTIONS:

- Remote control panel
- Redundant and hybrid power combined sub-systems
- Integral linearizer
- Integral block upconverter (BUC) - see TD-205 or contact CPI for specifications.
- LifeExtender™/LifePredictor
- Uplink Power Control
- External Receive Band Reject Filter (increases loss by 75 dB min. at bandwidth appropriate in relation to passband)

### FEATURES:

- Ethernet interface
- SNMP interface (v1, v2, or v3)
- Serial interface (compatible with CHPA)
- CAN-Bus architecture improves reliability and noise immunity.

Quality Management System - ISO 9001:2015



### Meets Global Requirements

Meets International Safety Standard EN-60215, Electromagnetic Compatibility 2014/30/EU and Harmonic Standard EN-61000-3-2 to satisfy worldwide requirements. CE Marked.

### Worldwide Support

Backed by over 40 years of satellite communications experience, and CPI's worldwide 24-hour customer support network that includes more than 20 regional factory service centers.

T5UI-12 Specifications	Standard Band	Extended Band	High Ku-Band
Output Frequency	13.75 to 14.50 GHz	12.75 to 14.50 GHz	13.75 to 14.80 GHz
Output Power (min.) TWT Peak Power Flange Peak Power CW Power at Flange Max. CW Power at Flange	1250 W (60.97 dBm) min. 1100 W (60.41 dBm) min. 540 W (57.33 dBm) min. 600 W (57.78 dBm) max.		
Note on Output Power	<i>This amplifier guarantees 540 W of CW power at the flange. The peak power specifications are provided so that desired backoff may be more easily calculated.</i>		
Gain	70 dB min.		
RF Level Adjust Range	0 to 30 dB (via PIN diode attenuator), 0.1 dB steps		
Gain Stability Over temp, constant drive Over $\pm 10^{\circ}\text{C}$ , constant drive	$\pm 0.25$ dB/24 hour max, max. at constant drive and temperature, after 30 minute warmup 2.0 dB pk-pk max. at 48 dBm output power 1.5 dB pk-pk max. at 48 dBm output power		
Small Signal Gain Slope	$\pm 0.02$ dB/MHz max.		
Small Signal Gain Variation	1.0 dB pk-pk max. over any 80 MHz (1.5 dB pk-pk max. with linearizer); 3.0 dB pk-pk max. across 750 MHz (4.0 dB pk-pk max. with linearizer)	1.0 dB pk-pk max. over any 80 MHz (1.5 dB pk-pk max. with linearizer); 4.0 dB pk-pk max. across 1750 MHz (6.0 dB pk-pk max. with linearizer)	1.0 dB pk-pk max. over any 80 MHz (1.5 dB pk-pk max. with linearizer); 3.5 dB pk-pk max. across 1050 MHz (5.0 dB pk-pk max. with linearizer)
Input/Output VSWR	1.3:1 max.		
Load VSWR	2.0:1 continuous operation; 1.5:1 for full spec. compliance; any value operation without damage		
Phase Noise	12 dB below IESS-308/309 profile; -47 dBc AC harmonic (100/120 Hz); -50 dBc AC fundamental (50/60 Hz); -47 dB sum of spurs (370 Hz to 1 MHz)		
AM/PM Conversion	2.5°/dB max. for a single-carrier at 57 dBm output power with optional linearizer (6°/dB without linearizer)		
Harmonic Output	-60 dBc at rated power, second and third harmonics		
Noise Density	<-150 dBW/4 kHz from 10.0 to 12.7 GHz; <-70 dBW/4 kHz, transmit band (<-65 dBW/4 kHz with linearizer option); <-105 dBW/4 kHz, 18 to 26 GHz; <-125 dBW/4 kHz, 26 to 40 GHz	<-150 dBW/4 kHz from 10.7 to 12.2 GHz; <-70 dBW/4 kHz, transmit band (<-65 dBW/4 kHz with linearizer option); <-105 dBW/4 kHz, 18 to 26 GHz; <-125 dBW/4 kHz, 26 to 40 GHz	<-150 dBW/4 kHz from 10.0 to 12.7 GHz; <-70 dBW/4 kHz, transmit band (<-65 dBW/4 kHz with linearizer option); <-105 dBW/4 kHz, 18 to 26 GHz; <-125 dBW/4 kHz, 26 to 40 GHz
NPR	-19 dB at 4 dB OBO (wrt flange) with optional linearizer		
Intermodulation	-25 dBc or better at 54.3 dBm output power (270 W), with respect to each of two equal carriers; -25 dBc or better at 57.3 dBm output power (540 W) with optional linearizer, with respect to each of two equal carriers		
Group Delay	0.01 ns/MHz linear max; 0.001 ns/MHz <sup>2</sup> parabolic max; 0.5 ns pk-pk ripple max.		
Primary Power	Voltage: Single phase, 200-240 VAC $\pm 10\%$ ; Frequency: 47-63 Hz, 15 A max.		
Power Consumption	2.3 kVA typ. at 540 W output power		
Power Factor	0.95 min; 0.99 typ.		
Inrush Current	200% max.		
Ambient Temperature	-10°C to +60°C operating, -54°C to +71°C non-operating		
Relative Humidity	95% non-condensing		
Altitude	10,000 ft. with standard adiabatic derating of 2°C/1000 ft. operating; 50,000 ft. non-operating		
Shock and Vibration	Designed for normal transportation environment per section 514.4 MIL-STD-810G. Designed to withstand 20G at 11 ms (1/2 sine pulse in non-operating condition)		
Cooling	Forced Air with integral blower. Rear air intake and exhaust. Maximum external pressure loss allowable: 0.5" water column		
Connections	RF Input: Type N Female; RF output: WR-75 grooved waveguide flange; RF output monitor: Type N Female		
M&C Interface	RJ45 Ethernet, includes embedded GUI control; RS422/485, RS232 serial interface		
USB Port	Download/Upload software, logs		
Dimensions, W x H x D	19 x 8.75 x 24 inches (483 x 222 x 610 mm)		
Weight	78 lbs (35 kg) nom.		
Heat Dissipation	1,450 watts to duct; 350 watts to room		
Acoustic noise	68 dBA (as measured at 3 ft.) nom.		



**SMP Division**  
**Satcom Products**  
tel: +1 (669) 275-2744  
email: [satcommarketing@cpii.com](mailto:satcommarketing@cpii.com)  
web: [www.cpii.com/satcom](http://www.cpii.com/satcom)

For more detailed information, please refer to the corresponding CPI technical description if one has been published, or contact CPI. Specifications may change without notice as a result of additional data or product refinement. Please contact CPI before using this information for system design.

© 2020 Communications & Power Industries LLC. Company proprietary; use and reproduction is strictly prohibited without written authorization from CPI.